

Breakoutboard 4.4 for ESS Smoothstepper

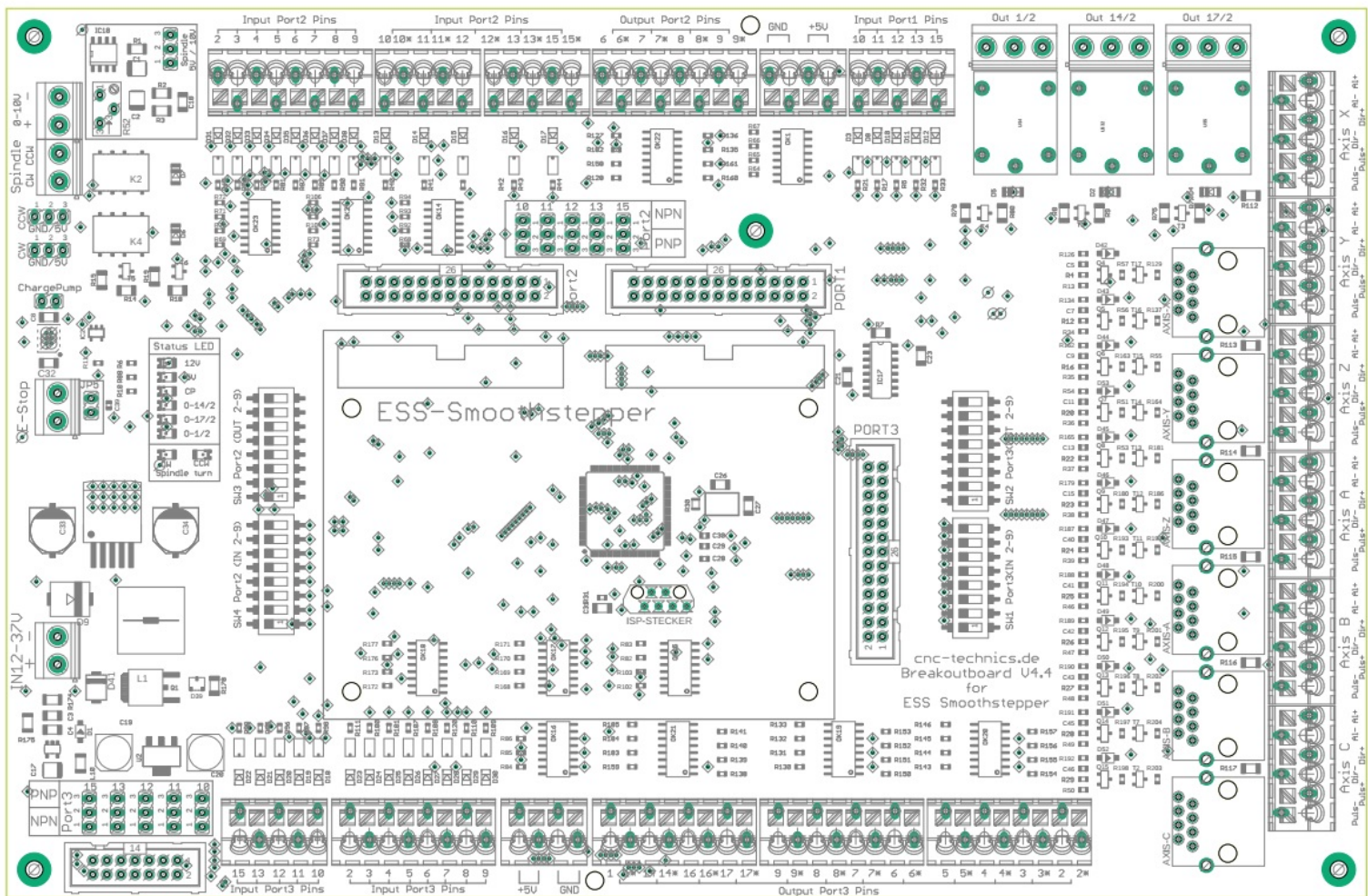

Operation Manual

All rights to these operating instructions remain with cnc-technics. Texts, information and illustrations of these operating instructions may not be reproduced, distributed or used for purposes of competition without authorization or communicated to others.

Table of Contents

Introduction	3
Description	4
Configuration	5
Commissioning.....	8
Inputs	9
Outputs	11
Adjust the Axes in Mach3	14
Adjust the Spindle in Mach3	15
Spindle direction.....	18
Solit State outputs.....	20
Status Display.....	22
Charge Pump	23
External Emergency Stop	24
Alarm Input	25

Introduction

This manual contains instructions for mounting, using the breakout board.

It is imperative to connect 230V connections by a knowledgeable electrician.

These operating instructions have been prepared with care. If you still find errors, we would be grateful for an indication.

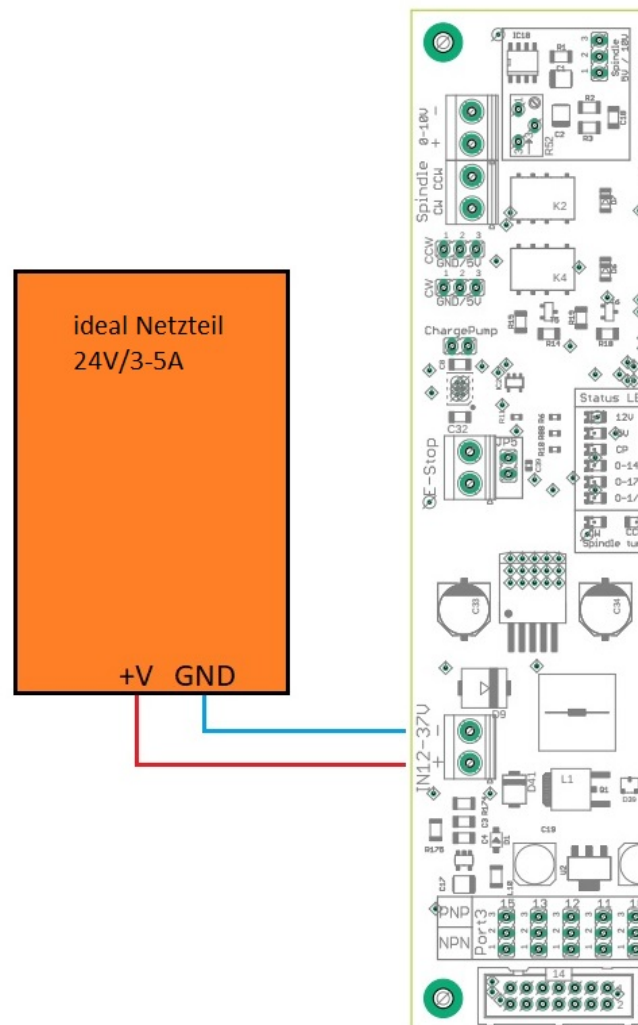

Please read the section
"Charge Pump" first, it is for
switching the board on and off

Description of the breakout board

The breakout board enables the operation of up to six stepper motor or servo output stages on the ESS Smooth Stepper.

For this the control Software Mach3 / Mach4 (not included) is used. The board has various inputs and outputs that can be individually set as many different configurations are possible. Depending on the selected configuration, additional functions are available, such as control of a frequency converter via an analog signal of 0-10V or 0-5V, reference switch, spindle direction relay, up to 3 relay outputs and one Charge Pump.

All signals are protected by Optocouplers. All machine-side signals are rated from 5V to 36V, ensuring robustness and compatibility even with industrial sensors (PNP & NPN SENSORS).

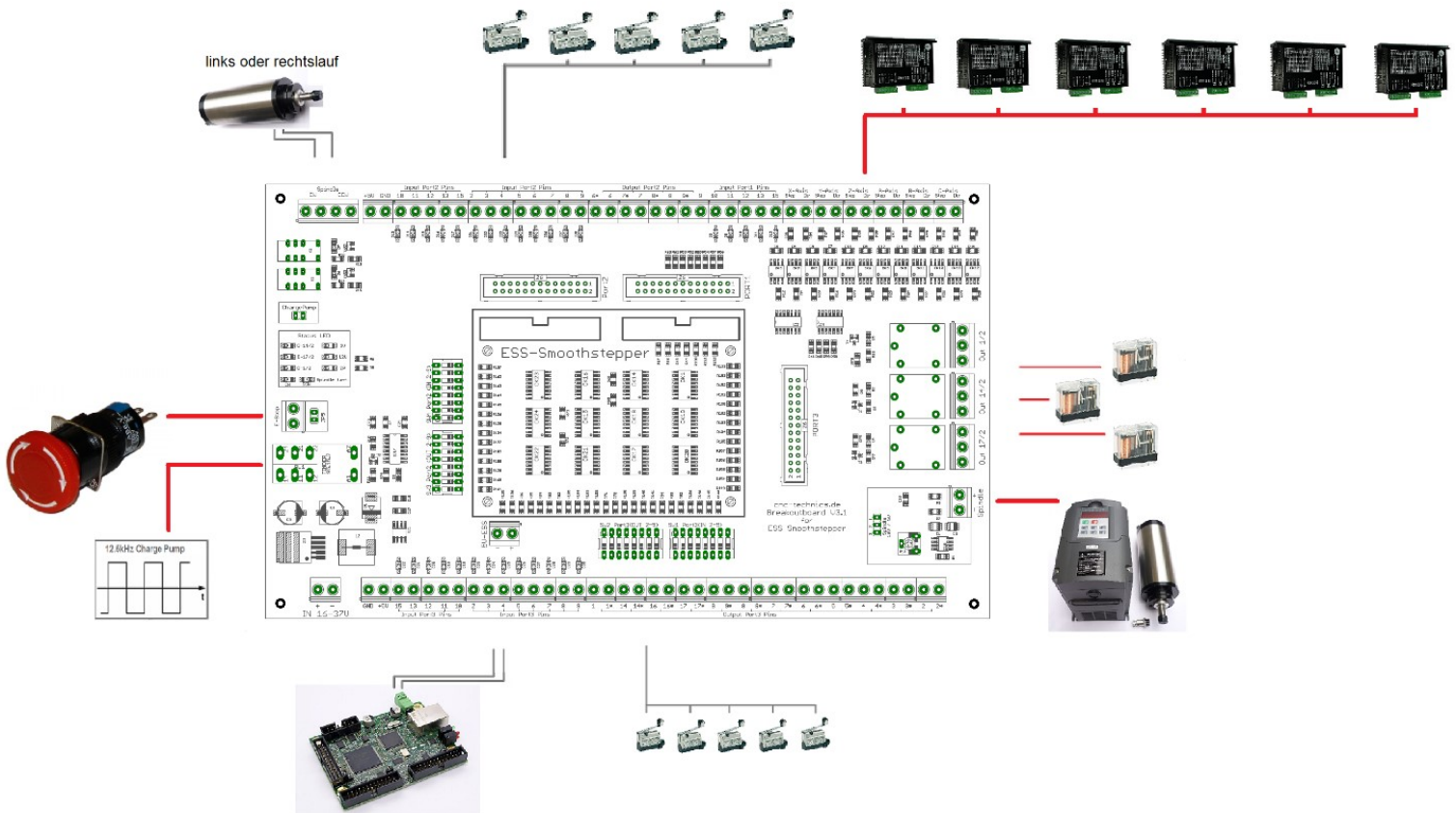

Configurations

Inputs and outputs which are fixed and can not be changed via the switches

Inputs: Pin 10,11,12,13

Outputs: Pin 1 (Spindle PWM),
Pin 2 (AxisX- Step), Pin 3 (AxisX-Dir)
Pin 4 (AxisY- Step), Pin 5 (AxisY-Dir)
Pin 6 (AxisZ- Step), Pin 7 (AxisZ-Dir)
Pin 8 (AxisA- Step), Pin 9 (AxisA-Dir)
Pin 14 (CW Relais)

Pin 15 Alarm INPUT, Emergency Switch

Pin 16 (CCW Relais)

Pin 17 (Charge Pump)

Port2: Pin 10,11,12,13,15 **INPUTS**, Pins 2-9 **Inputs or Outputs**

Change to Output than

Pin 2 (AxisB- Step), Pin 3 (AxisB-Dir)

Pin 4 (AxisC- Step), Pin 5 (AxisC-Dir)

Pin 1 (Relay) **OUTPUT**

Pin 14 (Relay) **OUTPUT**

Pin 17 (Relay) **OUTPUT**

Port3: Pin 10,11,12,13,15 **INPUTS**

Jumper4 from
ESS must be
closed for Power

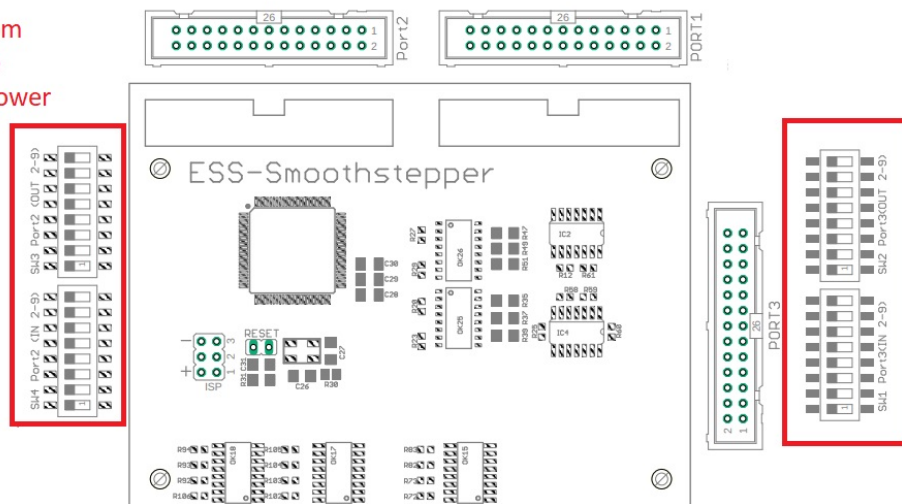

Port1: 5 Inputs **Pin 10/11/12/13/15**

Port2: 5 Inputs + 4 Outputs from Switch SW3 turn it **ON** - SW4 turn it **OFF**

Outputs Pin 6 / 7 / 8 / 9

Inputs Pin 10 / 11 / 12 / 13 / 15

The Smoothstepper configuration must be set to **OUT** at Port 2, so that the axes B and C are active

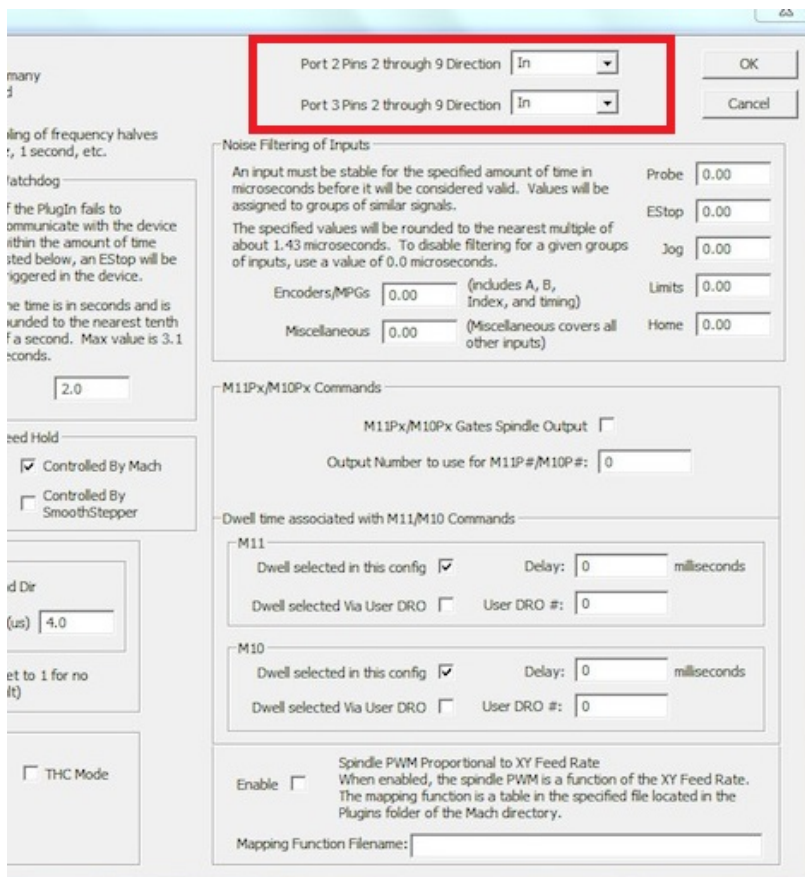

Port2: 8 Inputs + 5 Inputs from Switch SW3 turn it **OFF** - SW4 turn it **ON**

Inputs: Pin 2 – 9 , 10 / 11 / 12 / 13 / 15

The Smoothstepper configuration must be set to **IN** at port 2, which **disables** the A-C axes

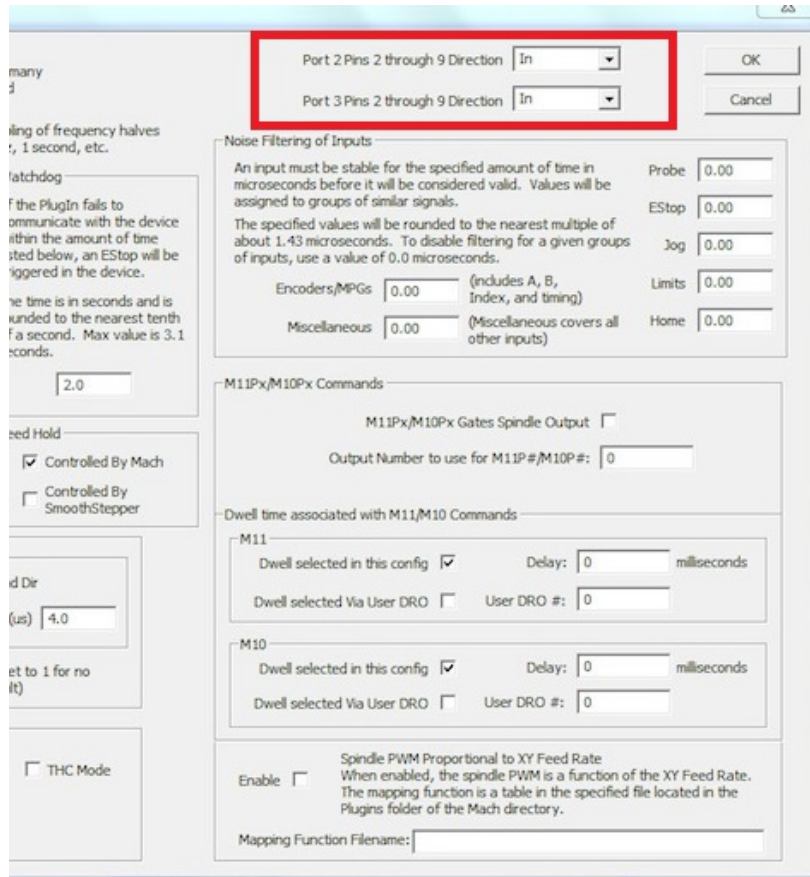

Port3: 4 Outputs + 5 Inputs + 8 Inputs from Switch SW2 turn it **OFF** – SW1 turn it **ON**

Inputs: Pin 2 - 9

Inputs: Pin 10 / 11 / 12 / 13 / 15

Outputs: Pin 1,14,16,17

The Smoothstepper configuration must be set to **IN** at port 3

OR

4 Outputs + 5 Inputs + 8 Outputs from Switch SW1 turn it **OFF** – SW2 turn it **ON**

Inputs: Pin 10 / 11 / 12 / 13 / 15

Outputs: Pin 2-9 , 1,14,16,17

The Smoothstepper configuration must be set to **OUT** at port 3

Commissioning

Installation of the Smoothstepper

- ➔ The smoothstepper is screwed on to the 4 spacer bolts with M3 screws
- ➔ **Jumper 4** from the Ess must be closed for Power 5V-ESS

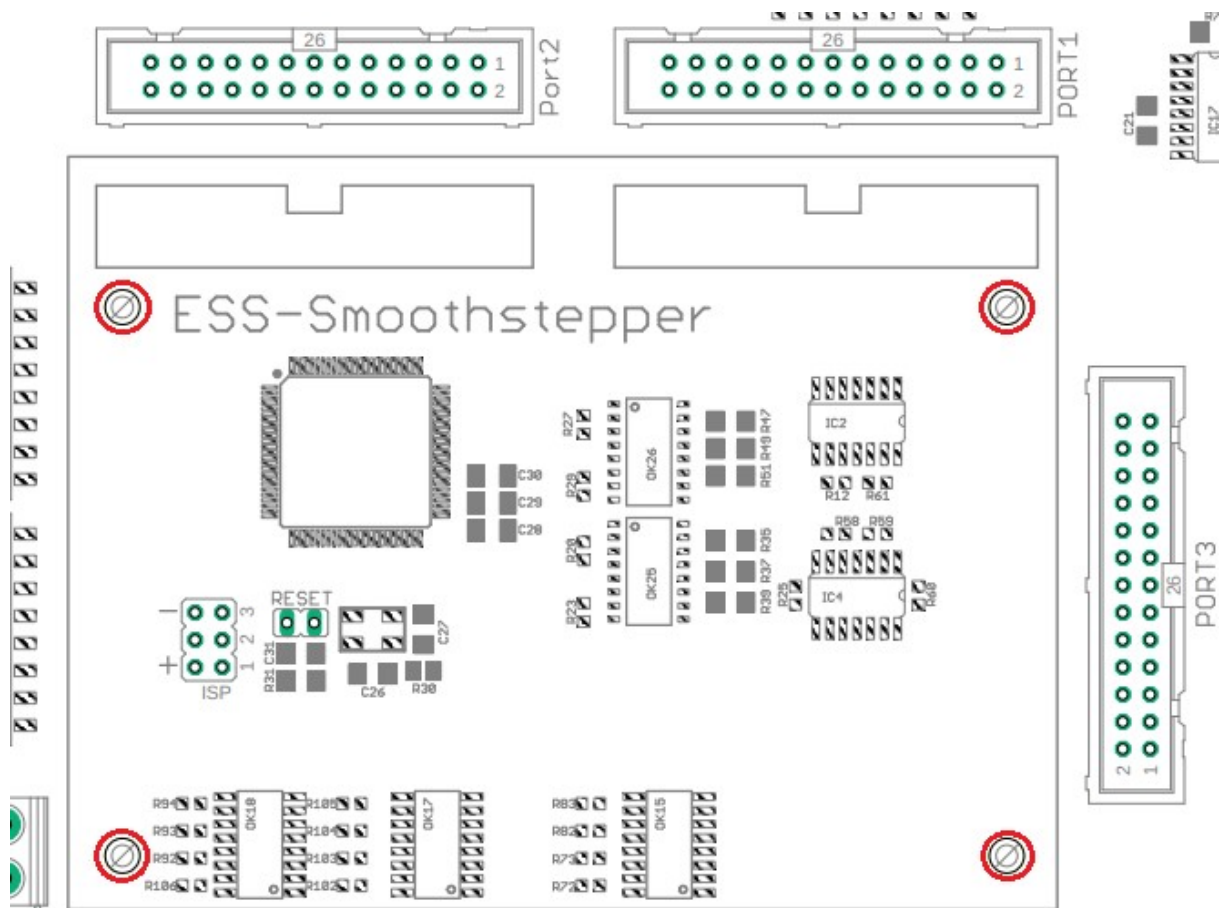

Inputs

Each input port is provided with its **Pin** number

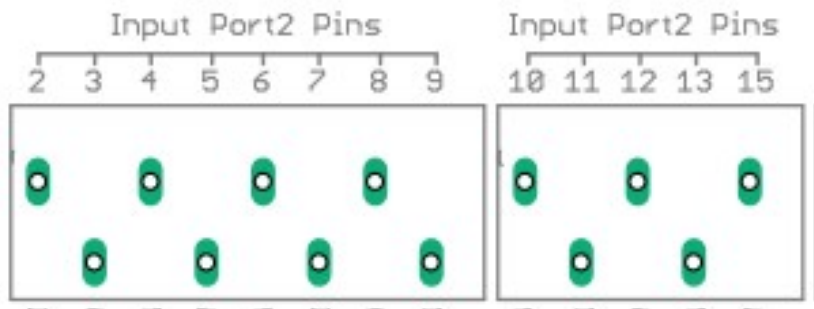

in Mach3 at Ports & Pins has to put a hook in **Active Low**.

When the limit switch is actuated, it internally switches to ground and Mach3 detects a response at the input. PNP sensors switch with the switching voltage so they are also direct connected.

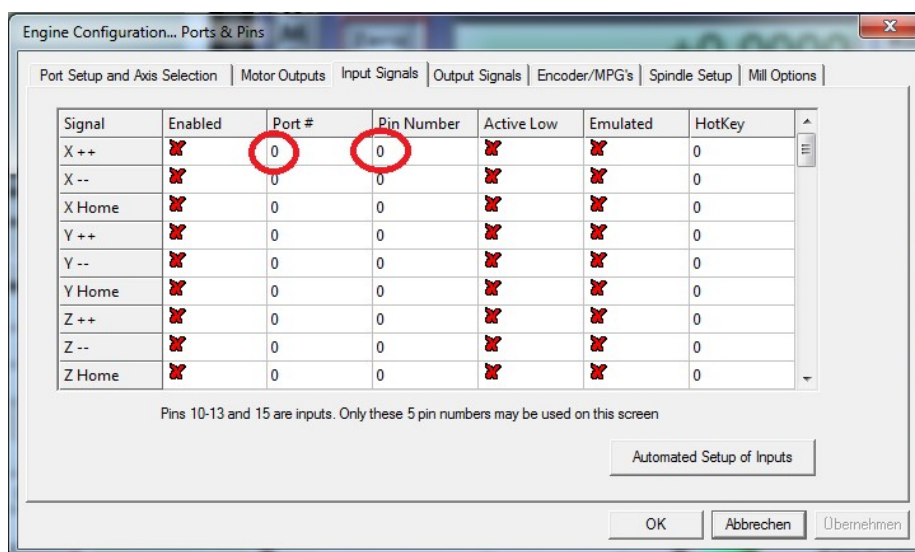
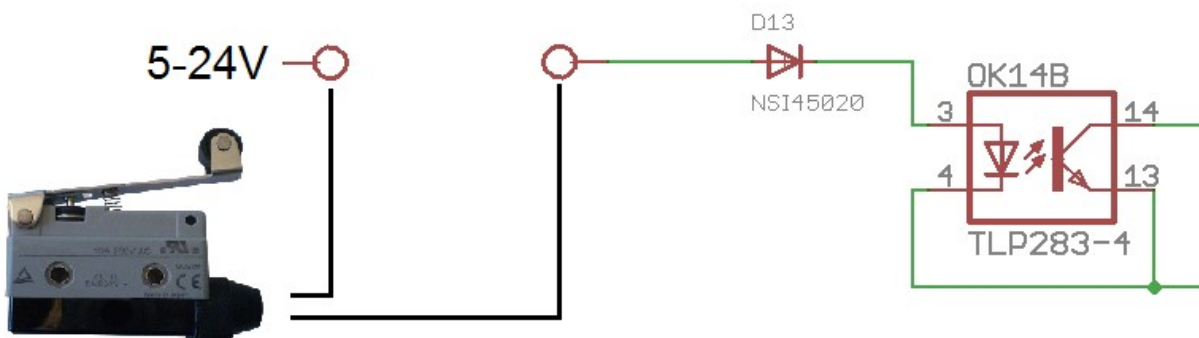

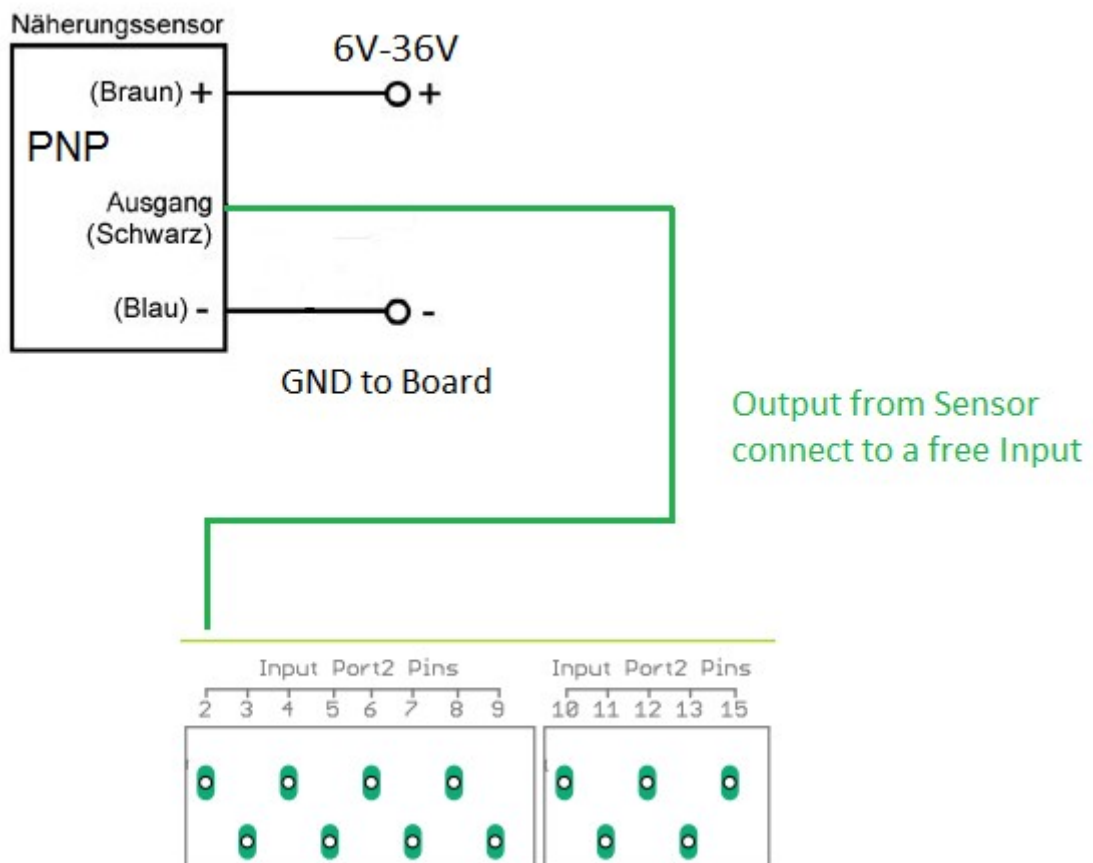
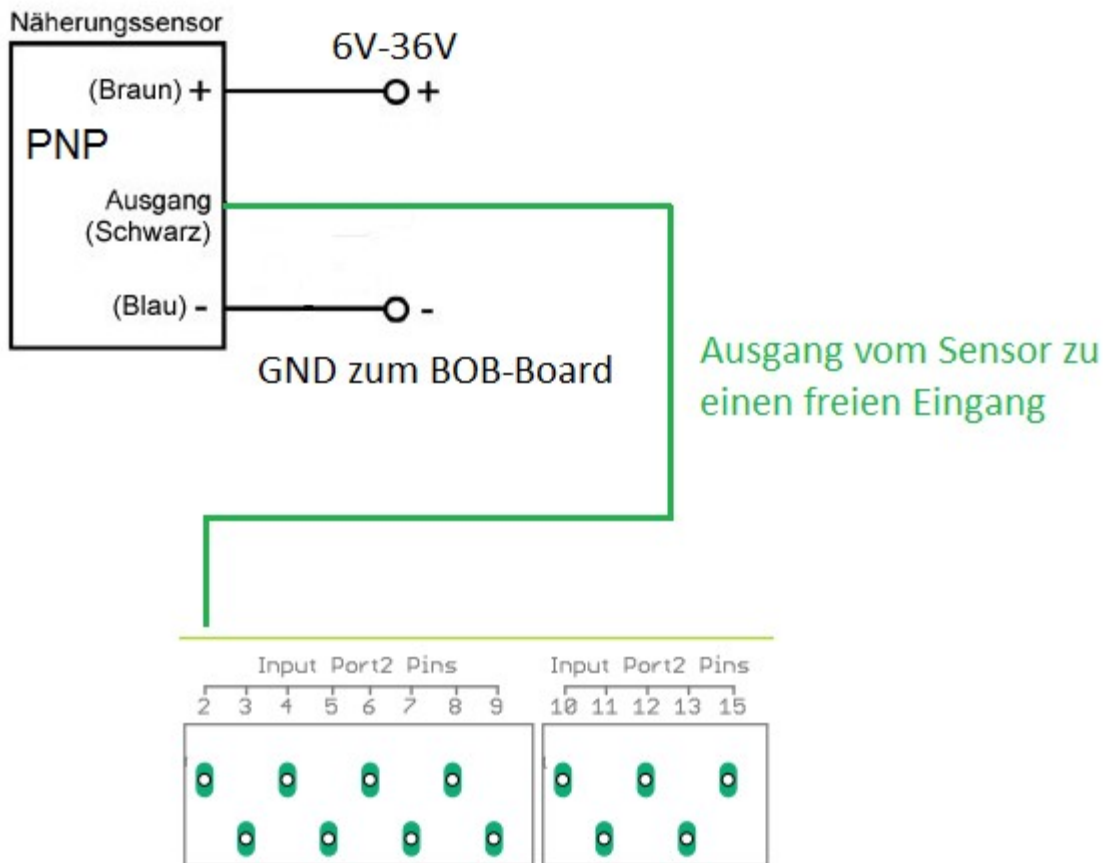

Sensorenumschaltung
für NPN oder PNP des
Port2
Pin 10,11,12,13,15

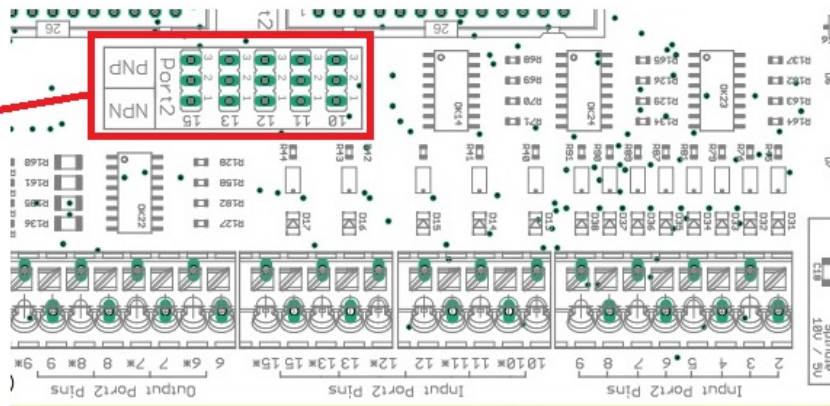

5V vom Board

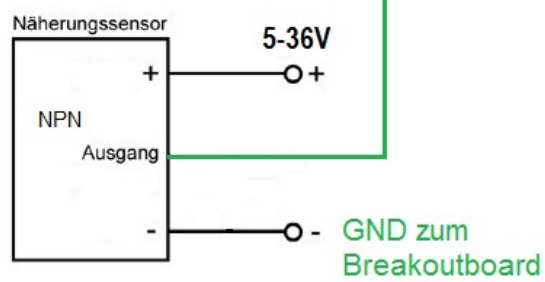

Outputs

Like the input port, each output port is also provided with a pin number and an associated * (output).

example

X32-1 is **Number 6 = Port2/Pin6** and

X32-2 is **Number 6* = Port2/Pin6**

For 5V sensors, relays or similar loads you can put a bridge of 5V on the respective pin number, so you can use a power supply.

For switching max **50mA** per output are available. If you need higher currents for switching you can connect inexpensive relay modules.

You can connect to any pin **without *** a direct voltage, max to 30V.

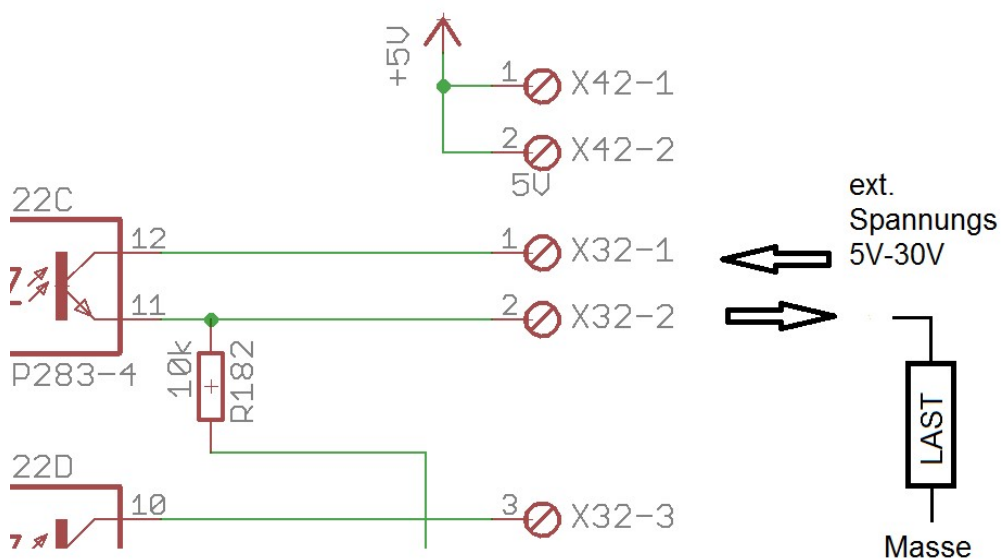
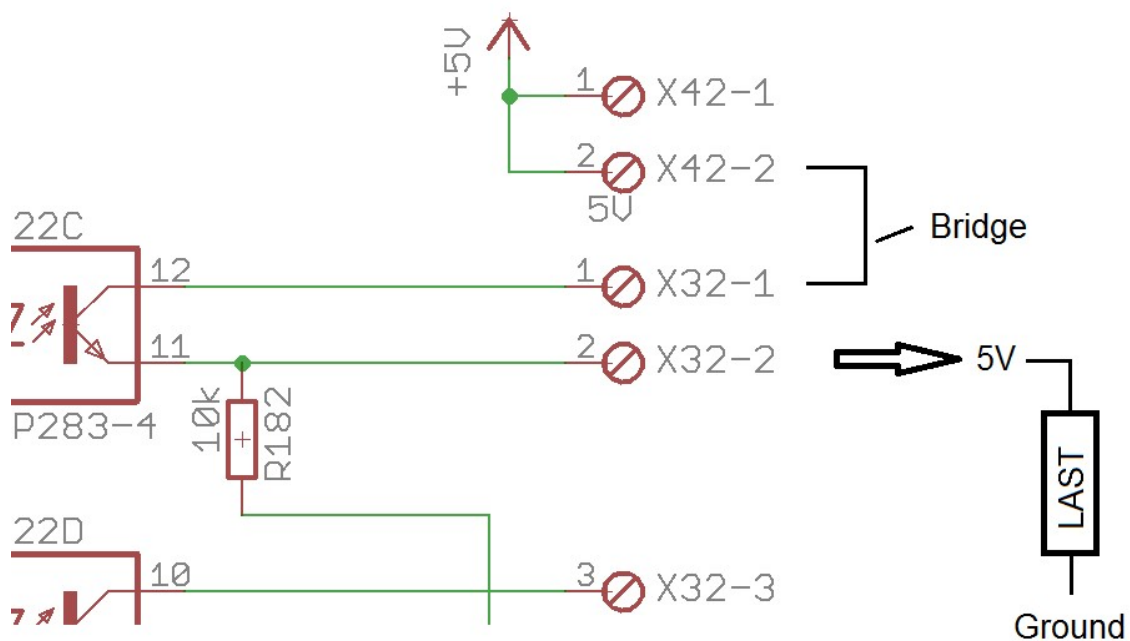

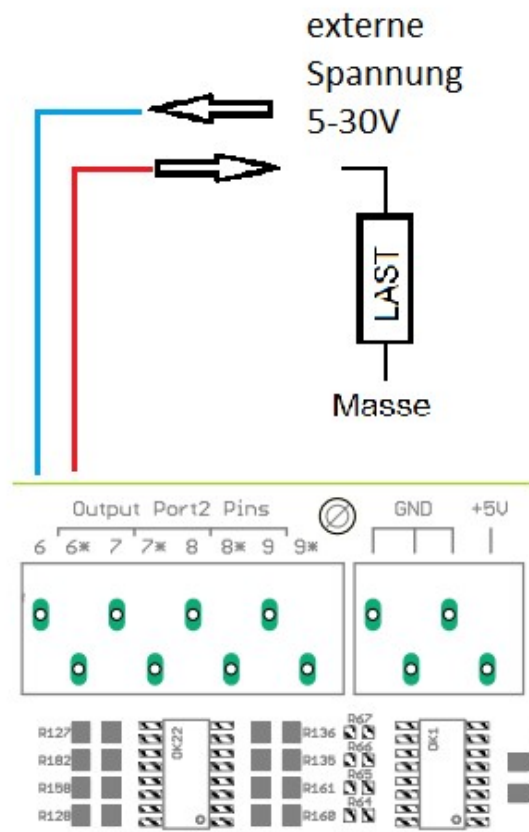
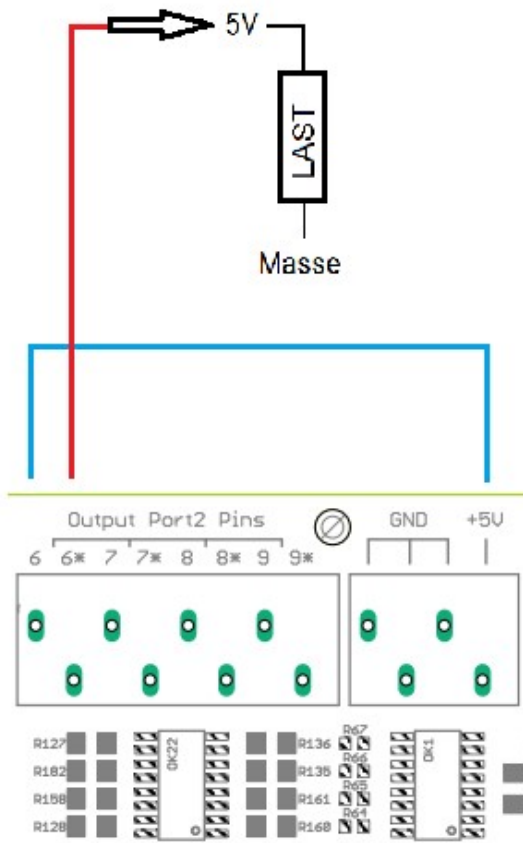

Integrate Outputs in Mach3

The Port Number and the Pin Number are used, the hook at enabled to enable output

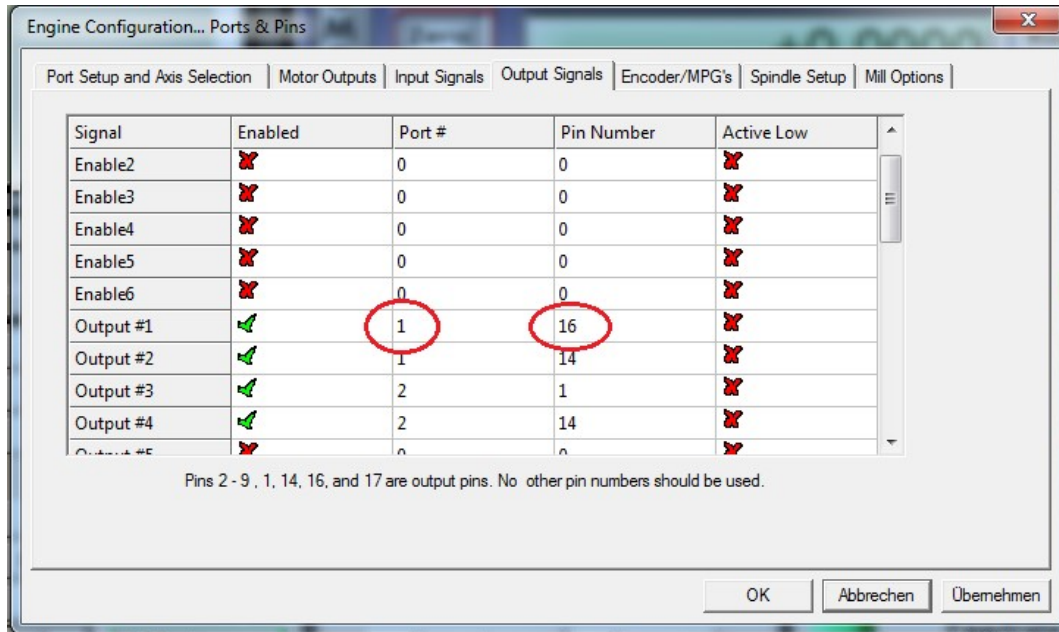

Set axes in Mach3

These are fixed values that should not be changed.

If you do not need axis B and C, you can deactivate them via switch SW3 and you can use as Input on port 2 of pin 2-9

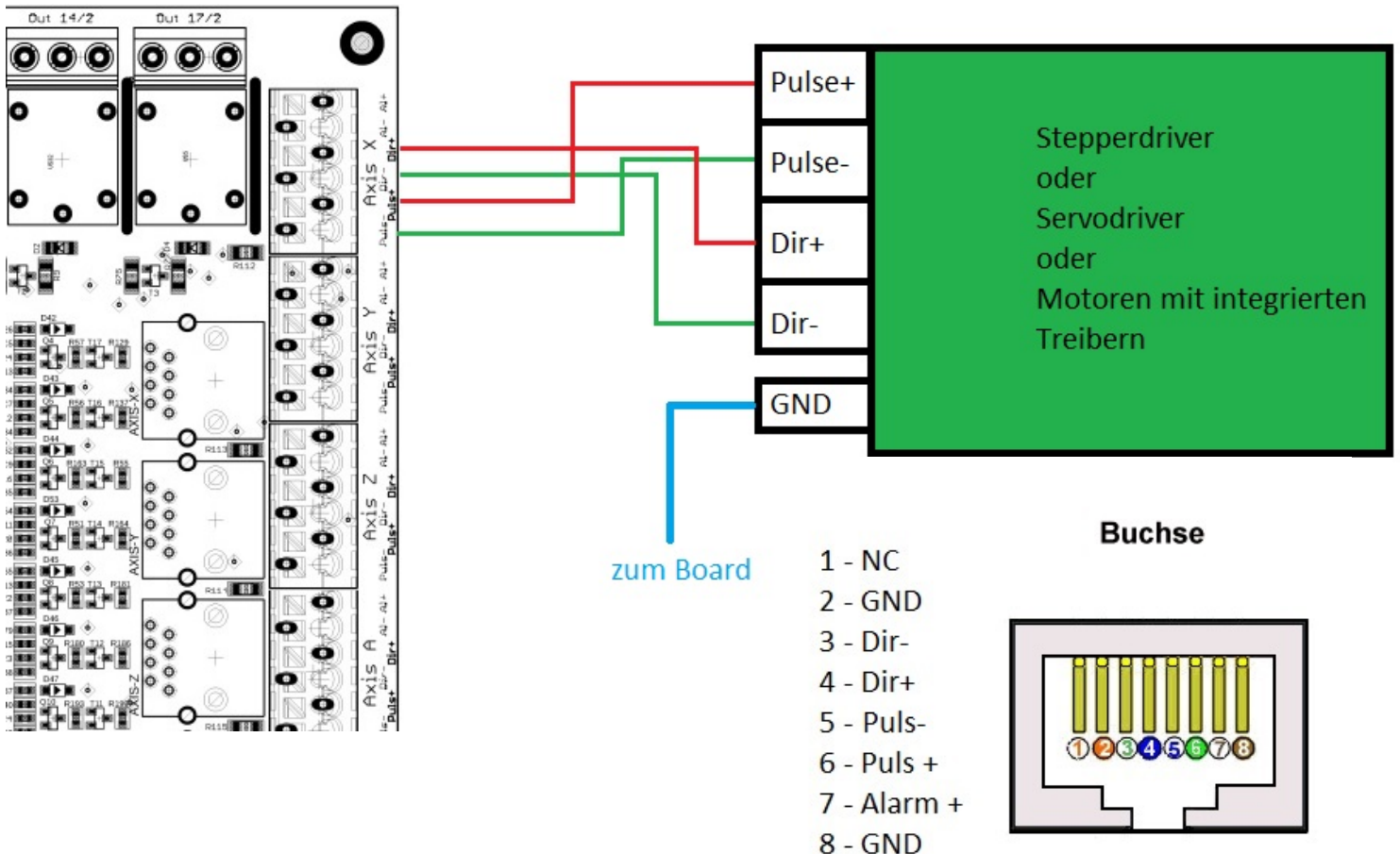
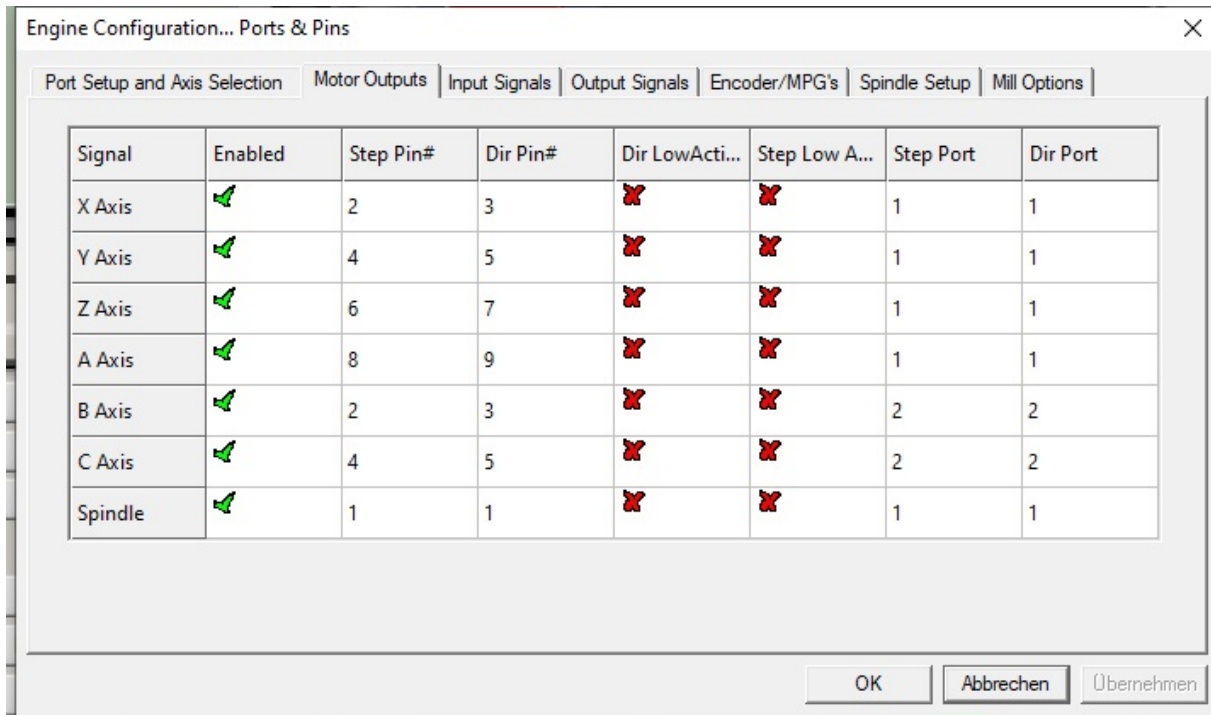

Set spindle in Mach3

Port 1 / Pin 1 is the analog output for the spindle speed

A VFD frequency inverter for the analogue signal can be connected to the spindle output. Via jumper 1-2 = 5V or bridge 2-3 = 10V output signal at bridge

The Potentiometer R13 should not be adjusted he is set so that at 5V PWM output from the PC comes a 10V analog signal

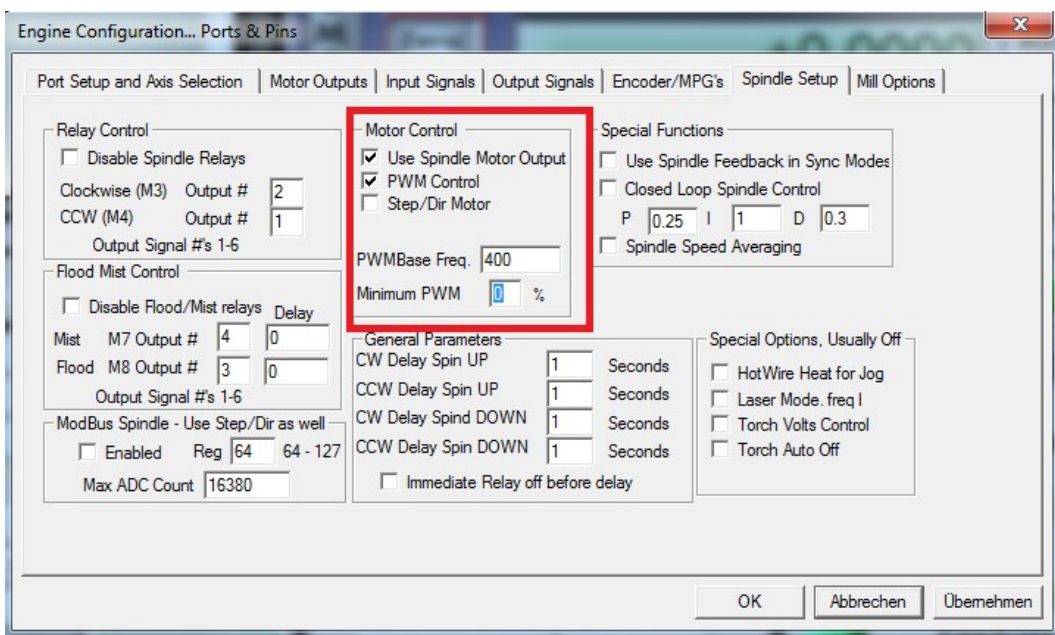
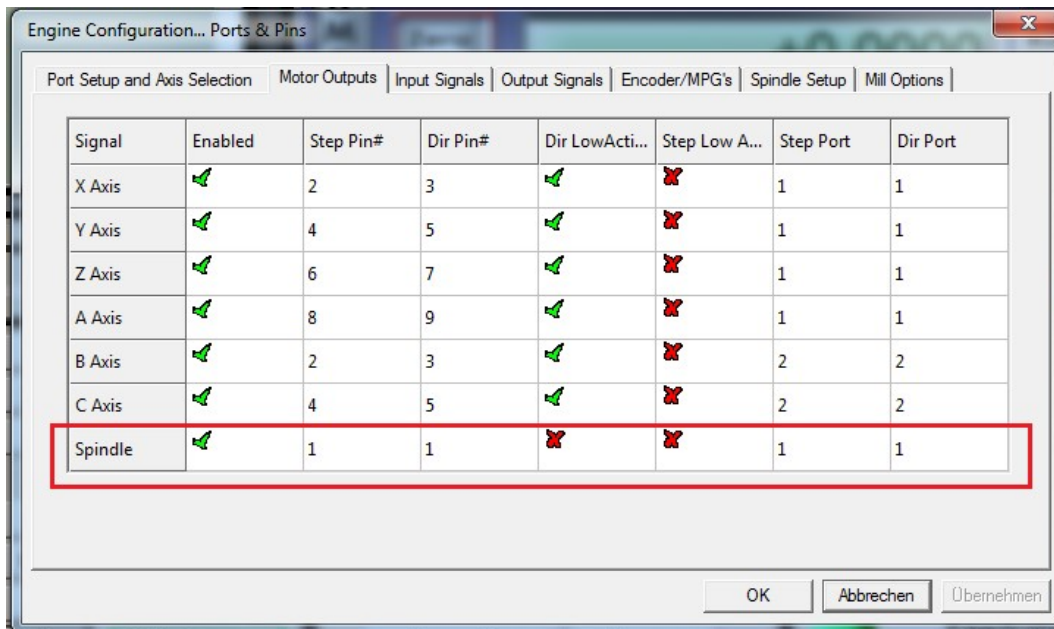
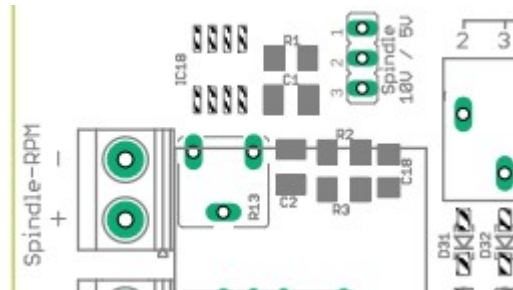

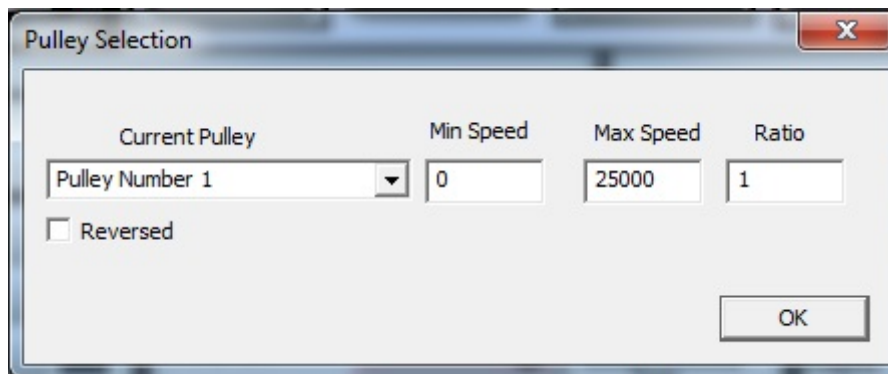
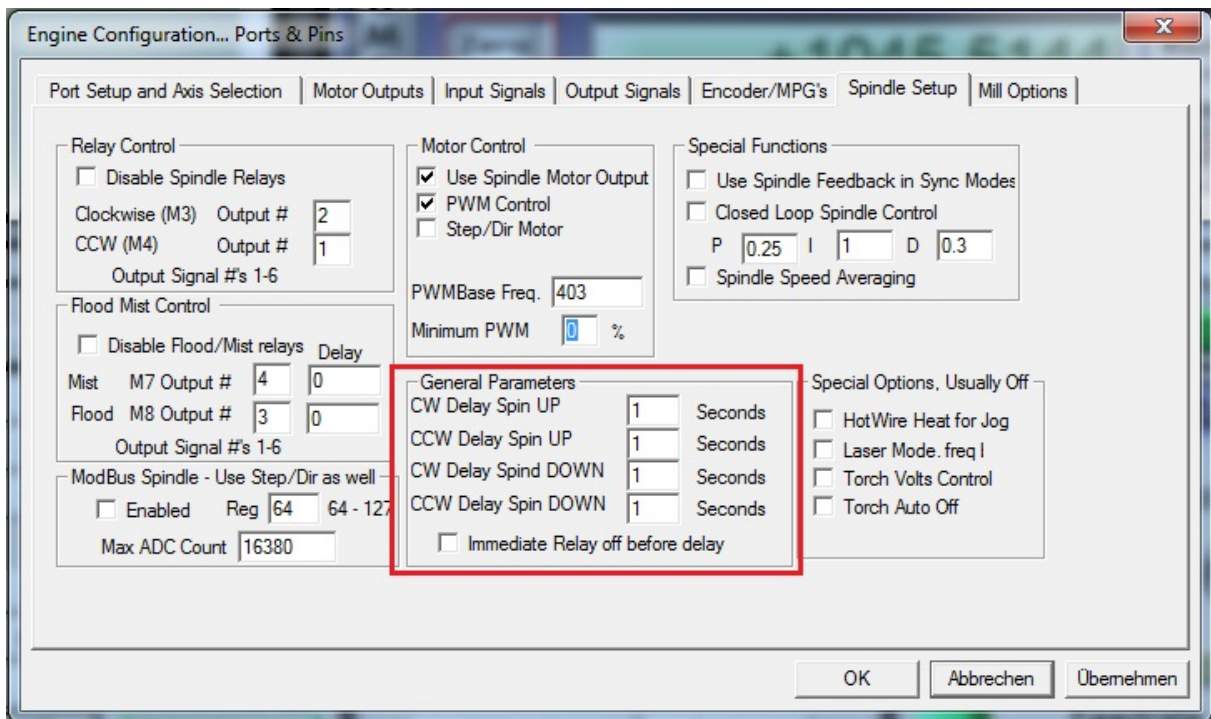
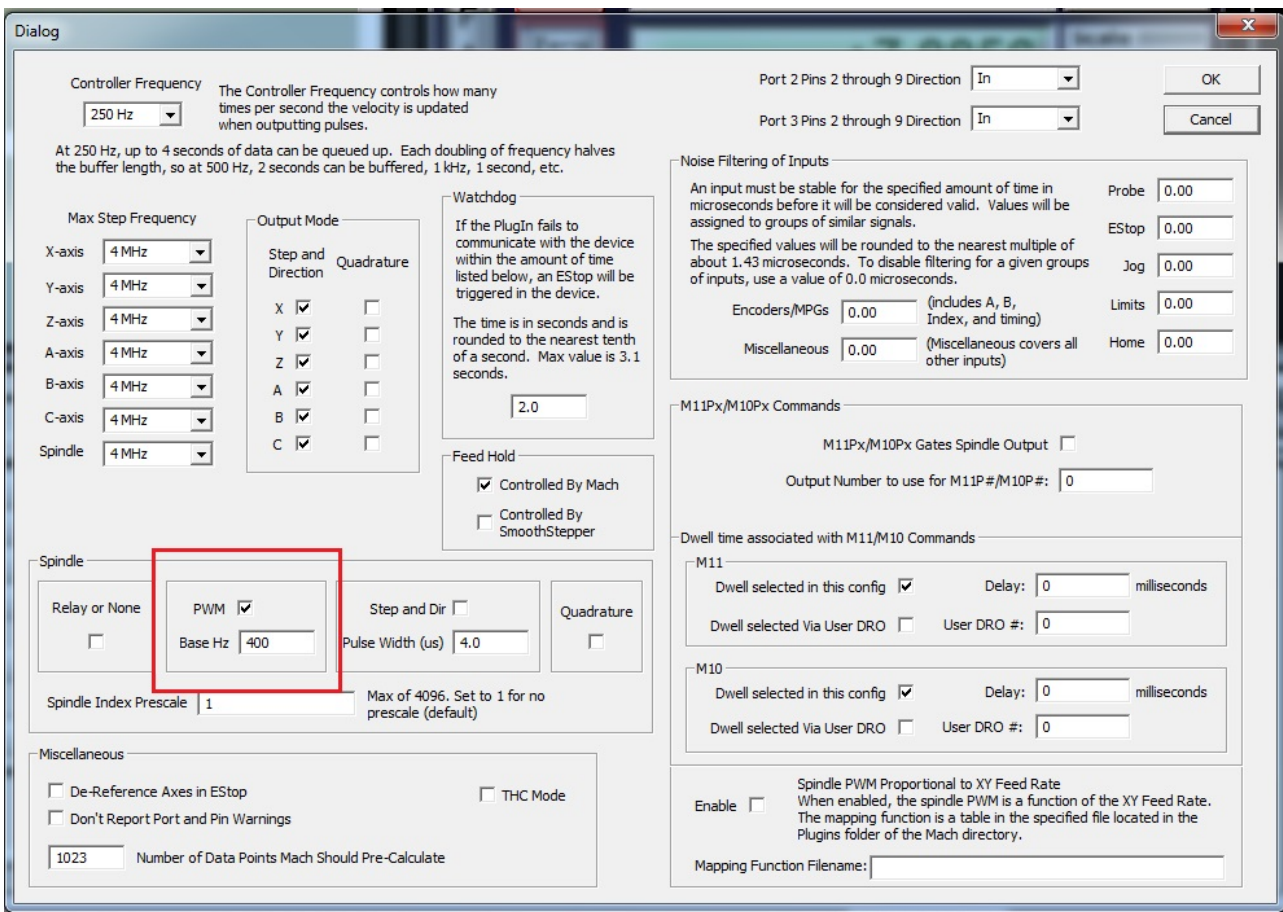

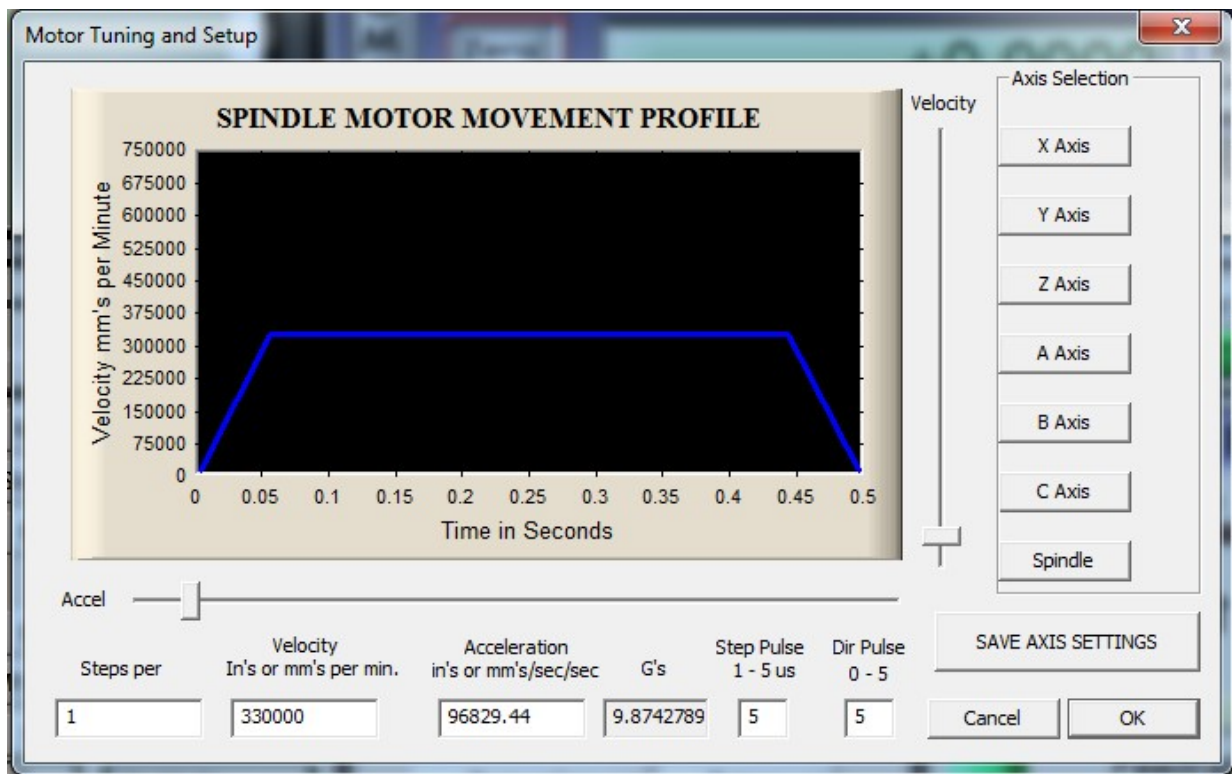

Spindle direction

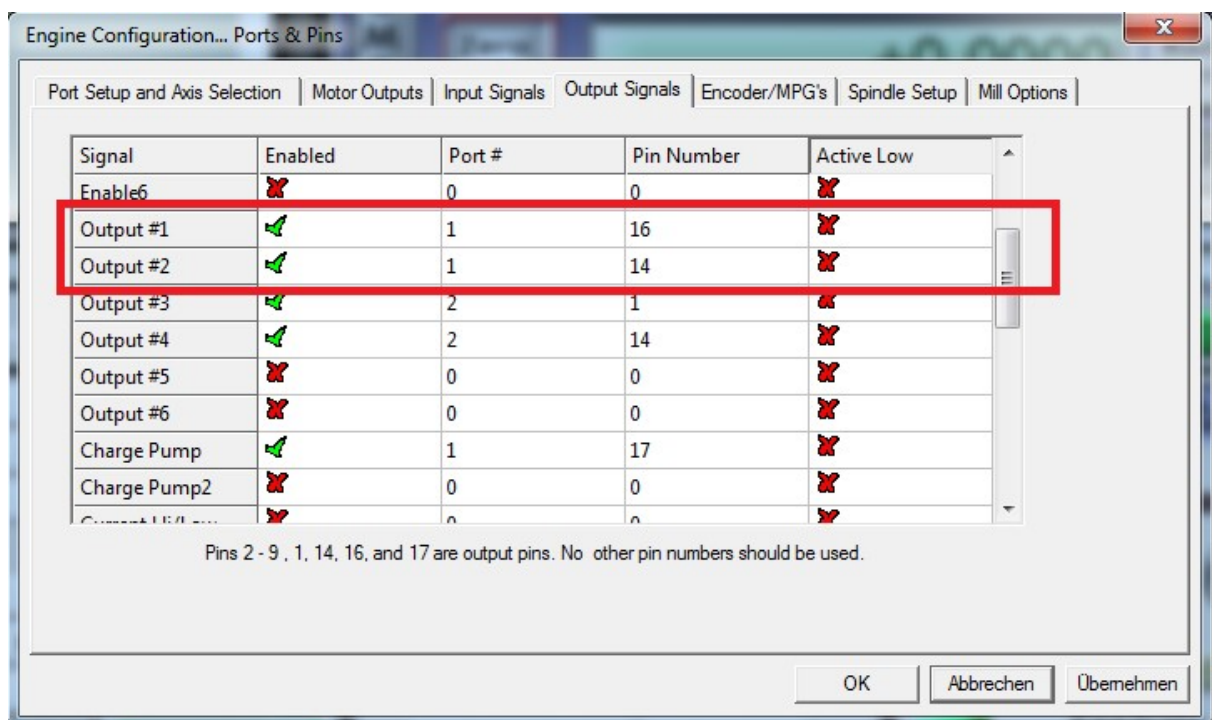
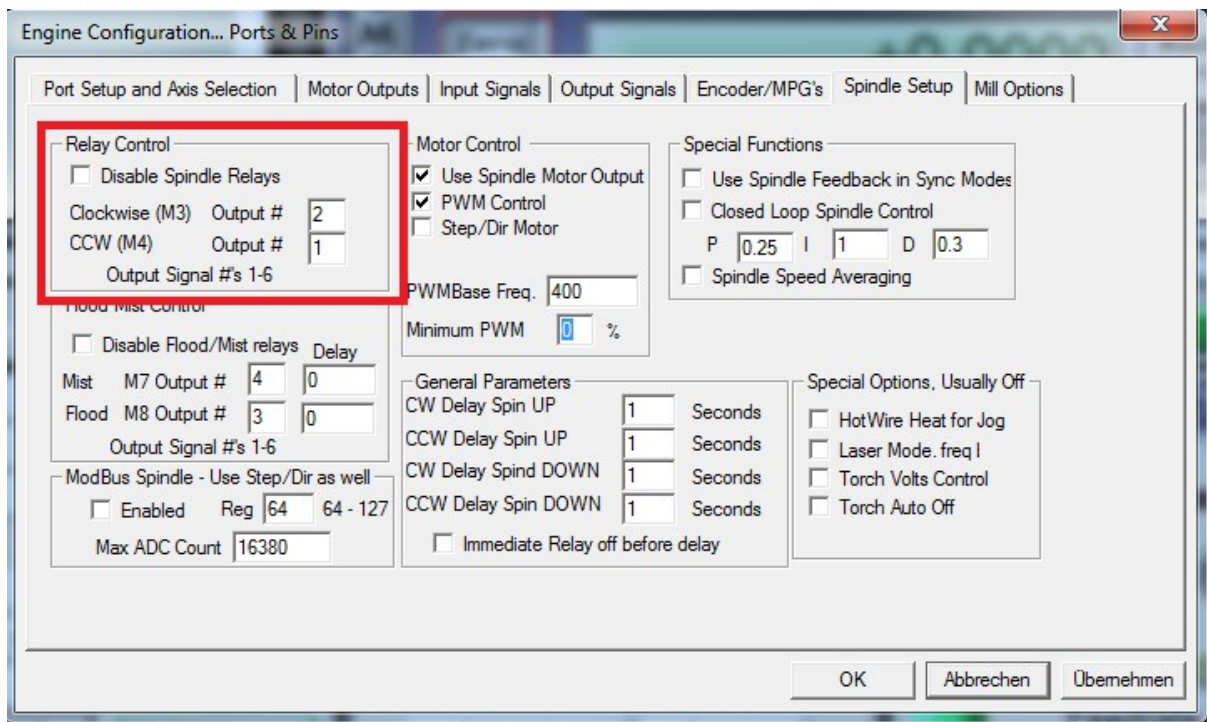

CW (clockwise) or CCW (counterclockwise) are switchable relay outputs.

From the CW and CCW Jumper can you switch that the Relais Outputs is to GND or to +5V
 You can with +5V another Relais switch.
Standart is to GND

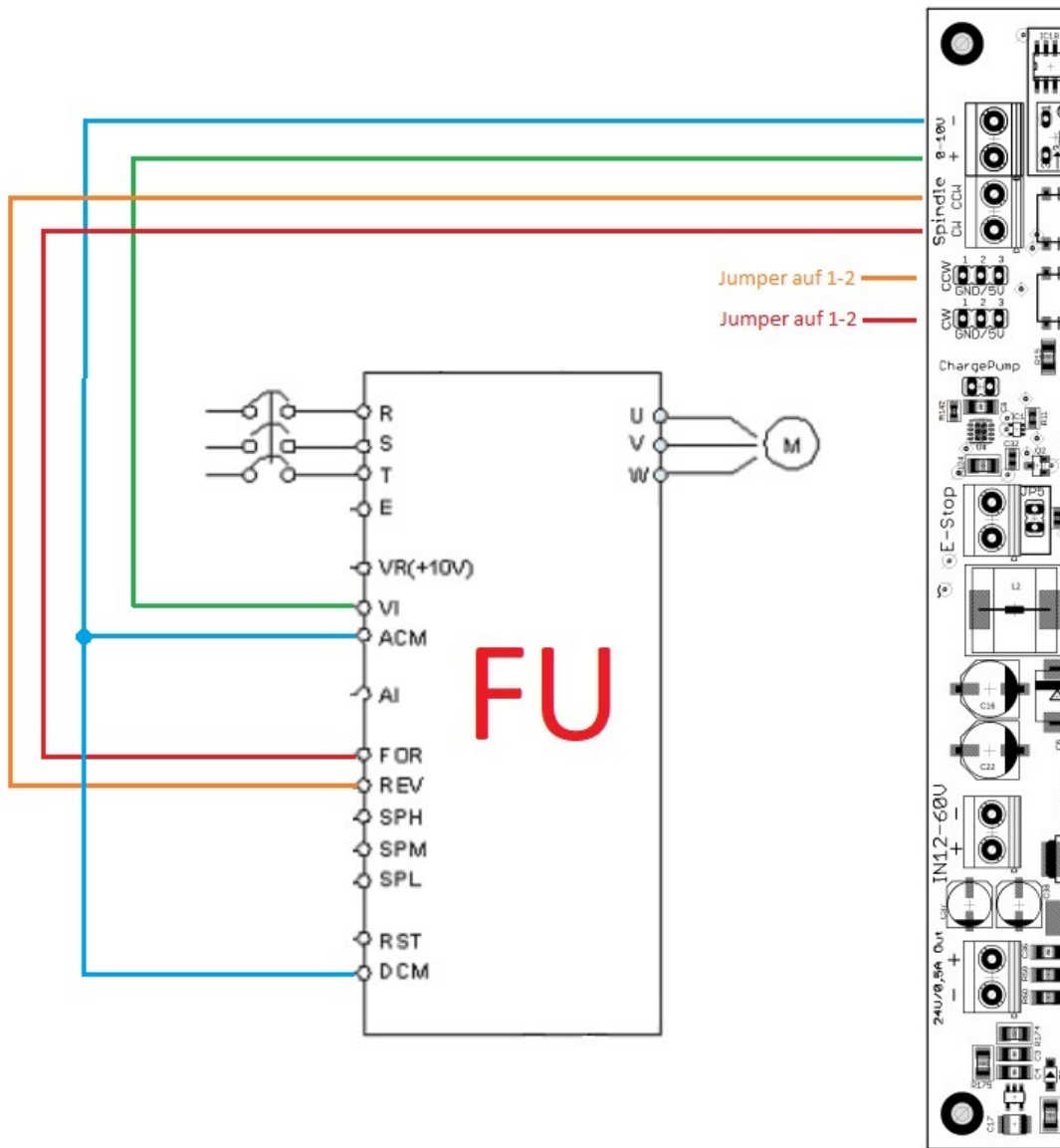
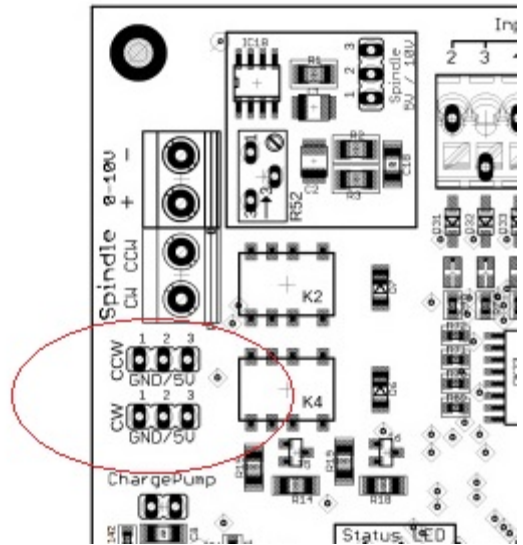

Relais Outputs

There are 3 Relay Outputs up to 230V / max 10A available PORT 2 → Pin 1,14 or 17

AC Power and DC Power

Attention: do not connect switching power supplies because they have a very high inrush current, the relay contacts may be defective

Relais not aktiv Modus

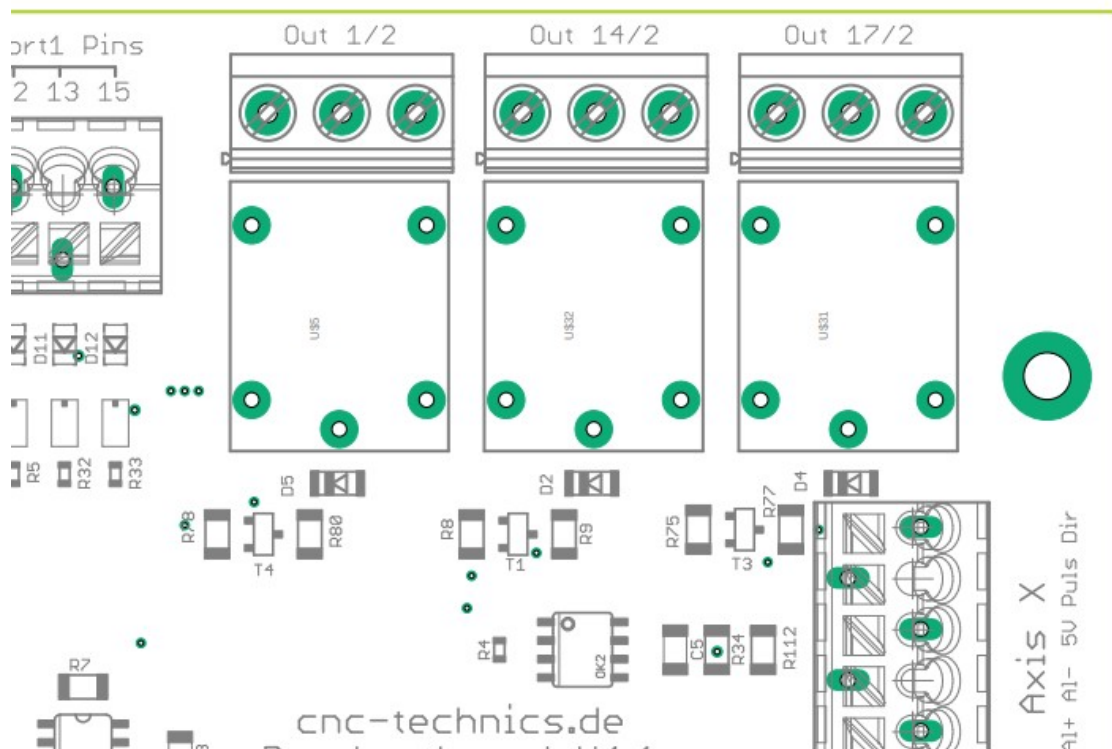
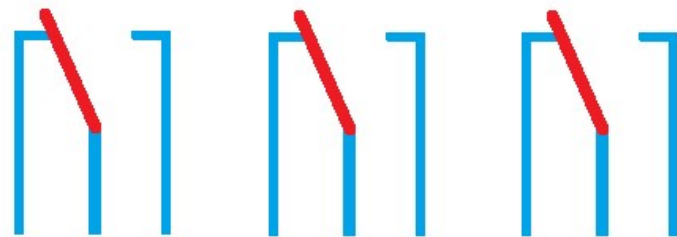

Charge Pump

This setting can be enabled or disabled

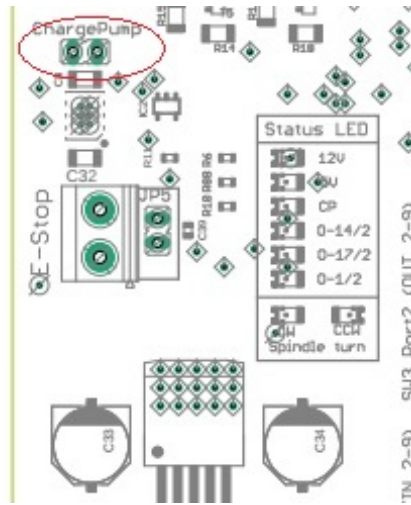

If the jumper is SET the board is activated without protection and all remain Tensions and controls are maintained even if Mach3 makes a reset.

If the jumper is NOT set, the breakout board will be controlled by Mach3 via the 12.5Khz signal. That is, only after the reset of Mach3 is deactivated, the board is active. All components are supplied with 5V or 12V. For this you have to make the following settings in Mach3:

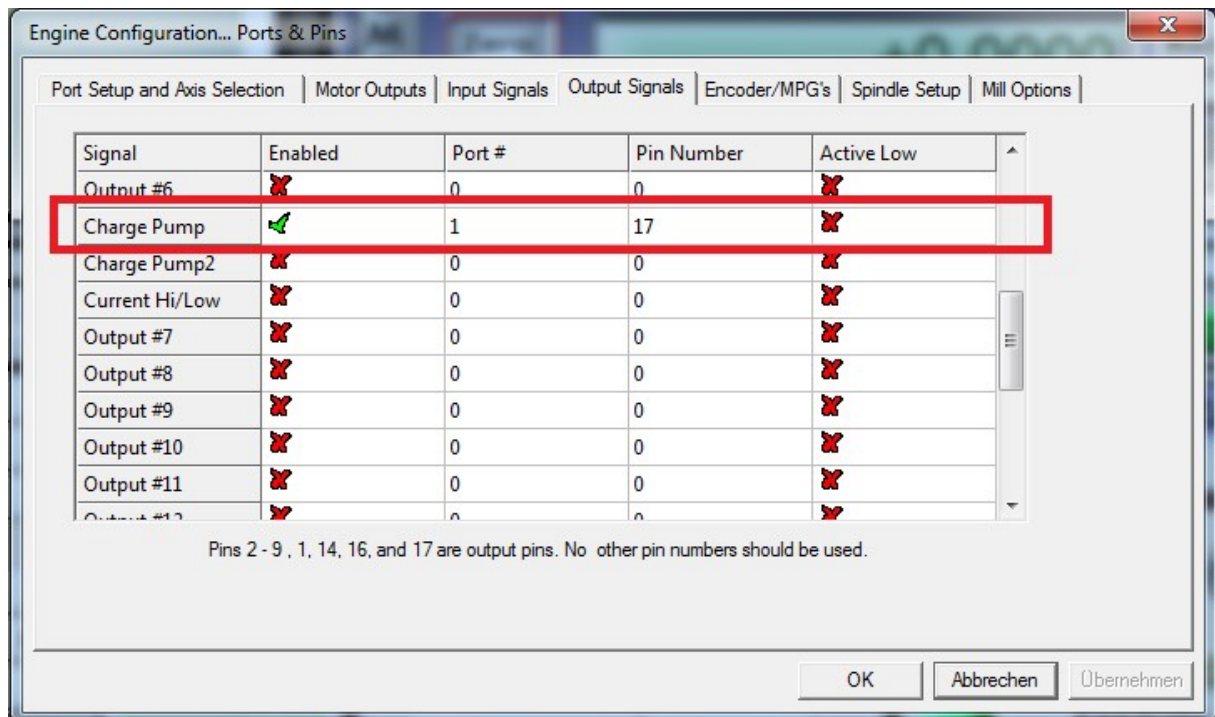

external Emergency Stop

The external emergency stop is connected as an opener and switches off Axis signals on the breakout board.

You must have a Emergency Stop with 1 Closer and 1 Opener. The Closer must be connected on Pin 15 from Port1

If you want to control an emergency stop via Mach3, the emergency stop has to be connected to an input which is defined under Ports & Pins in Mach3.

If Emergency Jumper is closed, the emergency stop is ignored.

Which is set in basic attitude so.

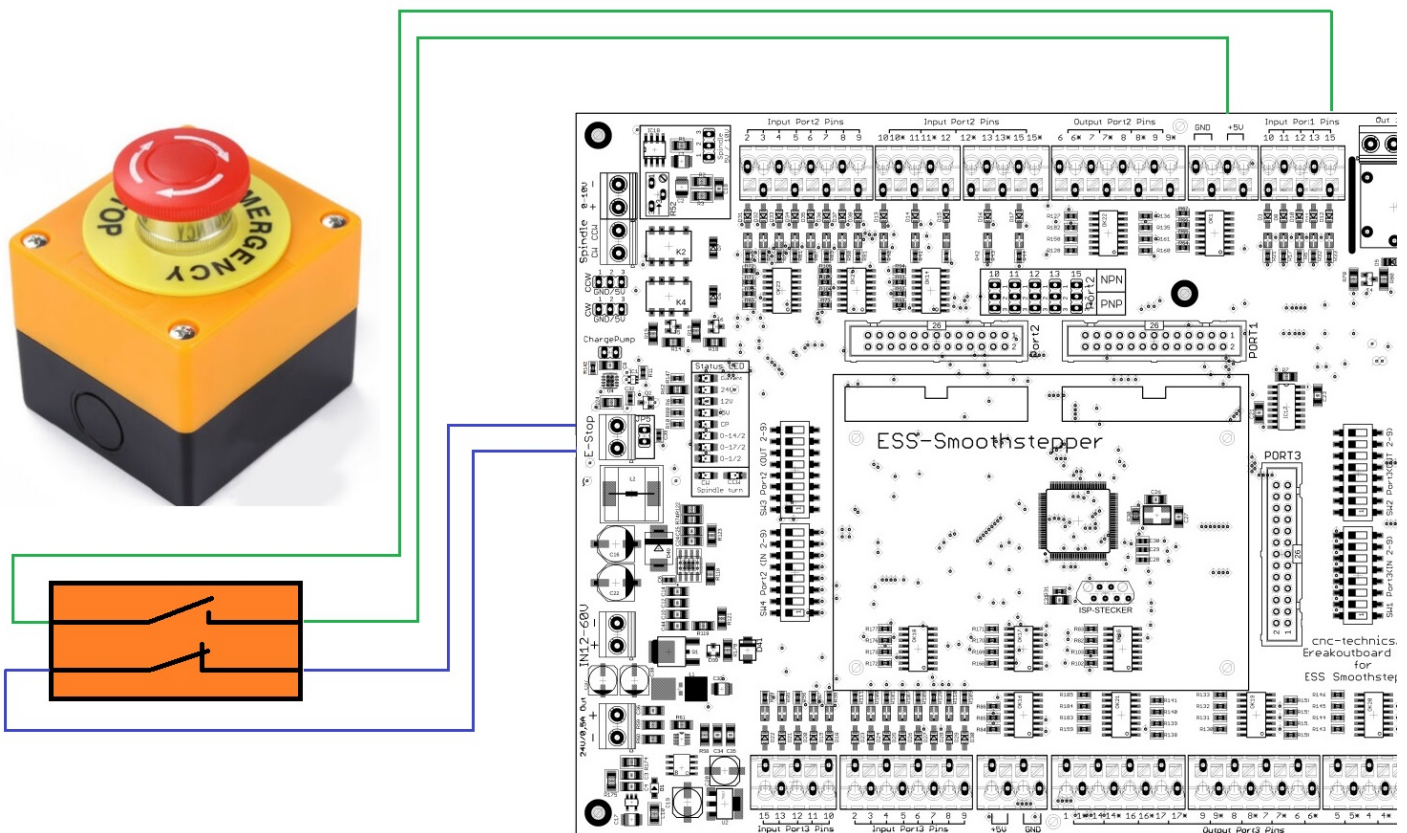

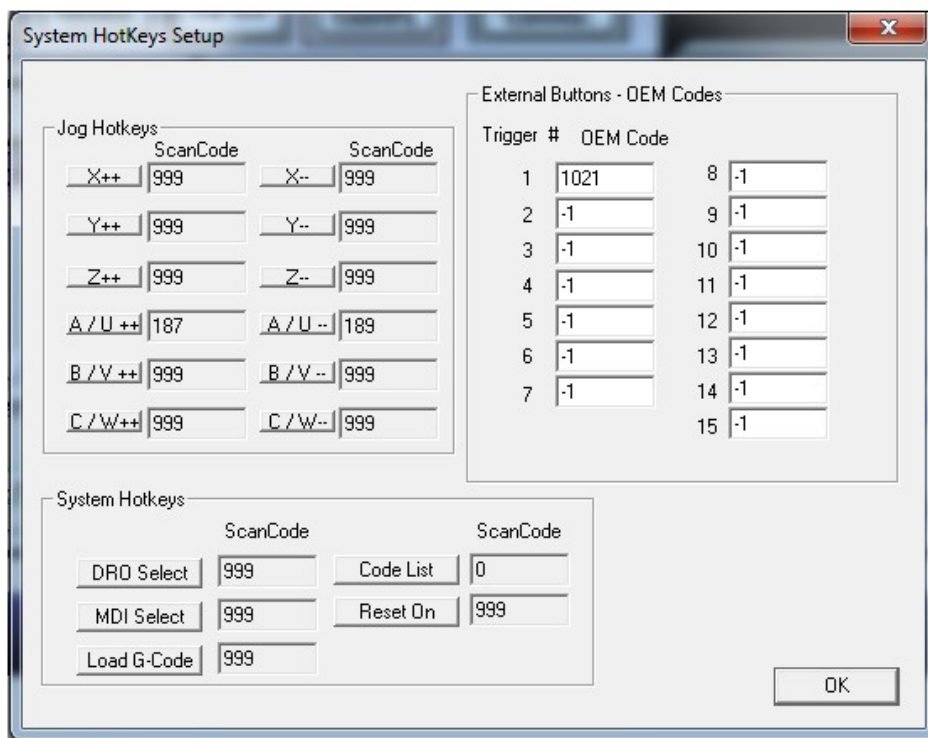
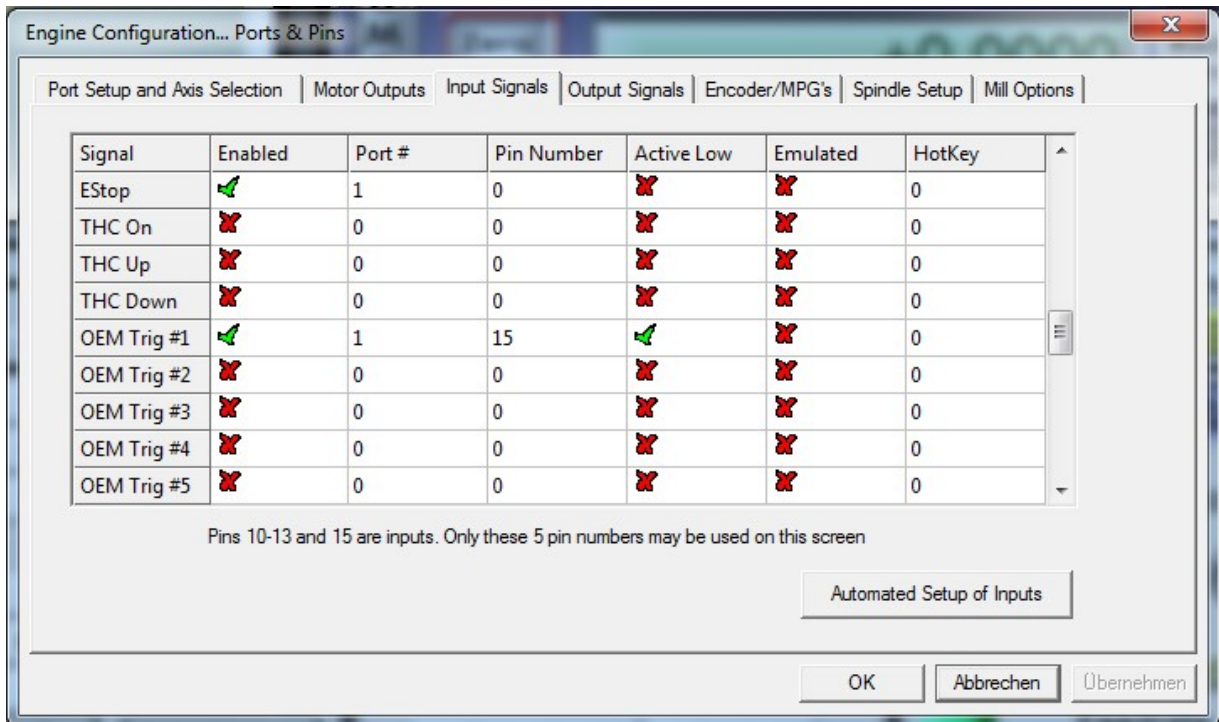

Trigger 1

1021 steht für Reset bei Alarm

man kann den Wert auch ändern z.b

in 1003 für Stop oder 1001 für Pause

Alarm output from example ServoMotor can also too be triggered by bridging

